

Multistage submersible drainage pumps for clear water and drainage water.

H 609, H 617

Application

HOMA H 609 and H 617 are multistage pumps with high pressure capability. With their 3 mm spherical clearance they are the ideal solution for high head pumping of surface water, rainwater and for irrigation from wells or tanks. Also suitable for many applications in industry, agriculture and private sector.

Installation: Transportable or permanent. Models with float switch control for automatic pump operation, depending on liquid level in the sump.

Pumped liquid: Clear water or drainage water containing soft solids. Max. liquid temperature: 40°C, short term up to 60°C.

Operation: Intermittent.

Design

Fully submersible, compact integrated motor-pump unit consisting of:

Pump: Multistage centrifugal pump with horizontal discharge G 1 1/2" F.

Impeller: 2 closed multi-channel impellers, spherical clearance 3 mm.

Motor: Fully submersible, pressure tight electric motor, oil-filled. Insulation class H. Motor protection IP 68. Cable connection chamber totally isolated from motor housing.

Cable: H 07 RN-F 4 G 1,5
Model 609W: H 07 RN-F 3 G 1
Model 617WA: H 07 RN-F 5 G 1,5

Shaft/Bearing: Large diameter stainless steel rotor shaft, pre-lubricated bearings.

Seals: Combination of mechanical seal and lip-seal.

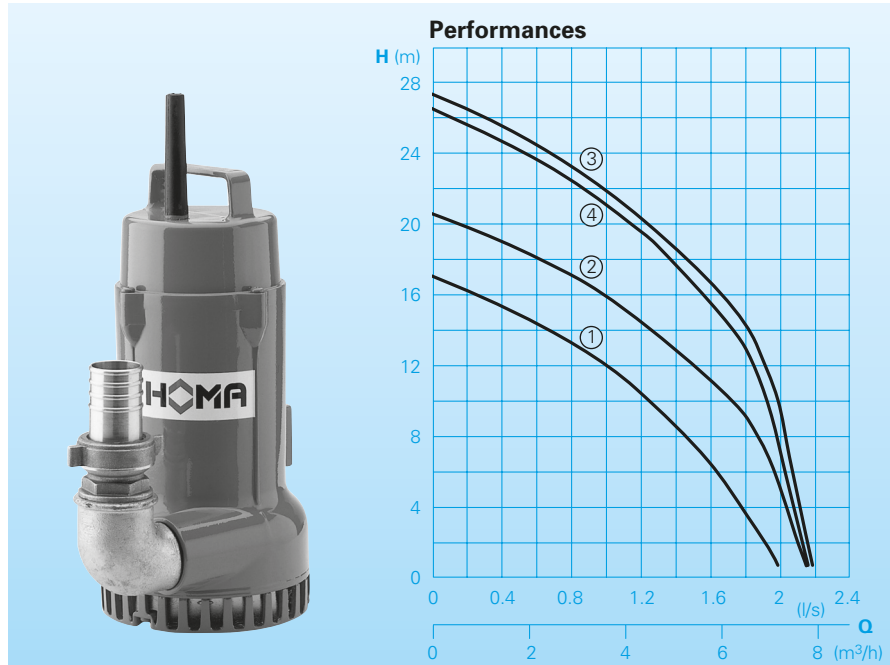

Technical Data

Curve No.	Pump type	Motor-input P ₁ (kW)	Motor-output P ₂ (kW)	Capacitor* (µF)	Voltage 50 Hz (V)	Nominal current (A)	Weight (kg)
①	H609 W (A)	0,8	0,56		230-240/Ph	4,4	11,0
②	H609 D (A)	0,85	0,64		400-415/3Ph	1,7	11,0
③	H617 W (A)	1,2	0,94	25	230-240/1Ph	5,7	14,0
④	H617 D (A)	1,2	0,94		400-415/3Ph	2,3	14,0

Speed: 2900 rpm

Model A: With automatic level control HOMA-Nivomatik

* **Capacitor:** For the operation it is necessary to install a capacitor in the control box.

Materials

Suction sieve and cover, feedback step, motor bearing housing, motor housing, motor housing cover	Aluminium
Impellers	Noryl
Rotor shaft, screws	Stainless steel
Mechanical seal	Silicon-carbide
Seal kit	Perbonane

Equipment supplied

Pump with 90° elbow BSP 1 1/2" M/F, fixed coupling BSP 1 1/2" M and hose coupling 1 1/4".

Model W (230-240V/1Ph): Supplied with control box W01; W19 fitted with overload protection, on-off-switch and 10 m of cable and plug. H617 additional with capacitor.

Model D (400-415V/3Ph): Supplied with control box D32 fitted with overload protection, on-off-switch and 10 m of cable and phase inverter.

Model A: With additional automatic level control, AS float switch, manual-auto-switch and control box WA/01; WA19; DA10/32.

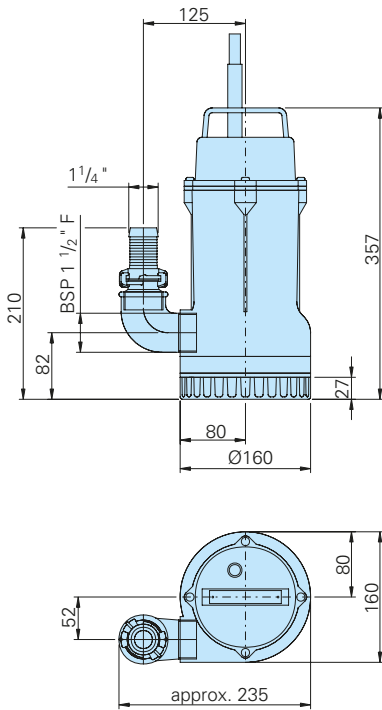

**Permanent installation
Single pump station**

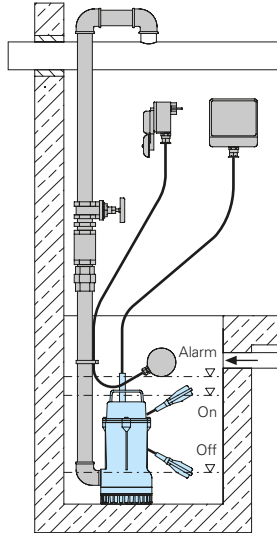

Twin pump station

Water level position of the float switch:
 A: float switch 1 normal position „ON“
 B: float switch 1 normal position „OFF“
 C: float switch 2 normal position „ON“
 D: float switch 2 normal position „OFF“
 E: alarm float switch „On“

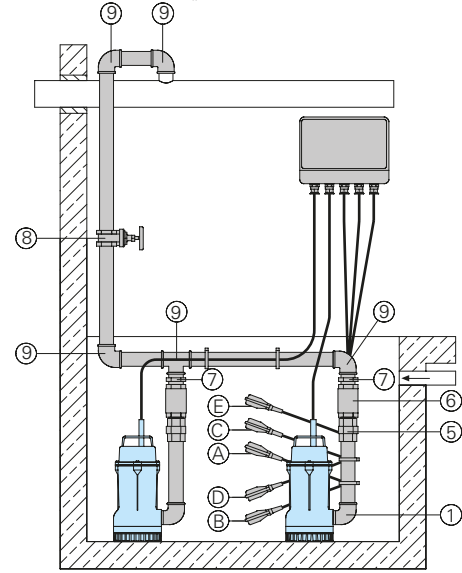

Accessories

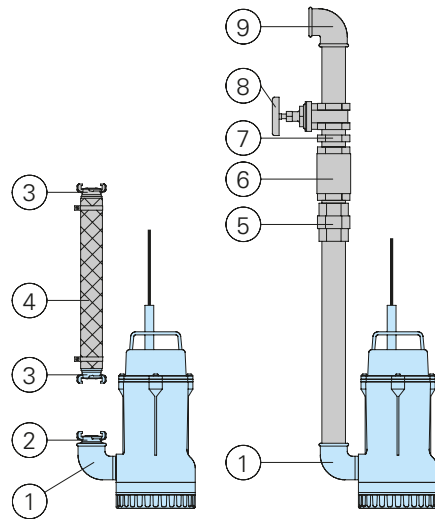

Part Description	Dimension	Part No.
① 90° galvanized elbow	BSP 1 1/2" F/M	Equipment supplied
② Brass fixed coupling	BSP 1 1/2" M	Equipment supplied
③ Hose coupling	1 1/4"	Equipment supplied
	1 1/2"	2003513
④ PVC-hose, per m	1 1/4" Ø 30 mm	2621200
	1 1/2" Ø 38 mm	2621500
⑤ Galvanized pipe union	BSP 1 1/4" M/F	2114304
	BSP 1 1/2" M/F	2114305
⑥ Bronze non-return valve	BSP 1 1/4" F	2211213
	BSP 1 1/2" F	2211313
⑦ Galvanized double nipple	BSP 1 1/4" M	2009011
	BSP 1 1/2" M	2009020
⑧ Bronze gate valve	BSP 1 1/4" F	2216012
	BSP 1 1/2" F	2216015
⑨ Galvanized 90° elbow	BSP 1 1/4" F	2113604
	BSP 1 1/2" F	2113605
T-piece for twin-pump arrangement	BSP 1 1/4" F	2114301
	BSP 1 1/2" F	2114302

Part Description	Dimension	Part No.
○ HOMA-Nivomatik float switch level control, conversion kit -for 230-240 V/1Ph AZW 10/10	length 10 m	1430105
-for 400-415 V/3Ph AZD 10/10	length 10 m	1914452
○ Alarm device AL3 Mains-operated with connector for battery 9V (see below) for mains-independent operation with integrated buzzer. Mains connection 230-240 V/1Ph		1586140
Battery for mains-independent operation	9V	1952215
Float switch MB, mercury free, function on or off, with integrated counter weight		
Cable length	6 m	1465706
	10 m	1465710
○ HOMA 2 poles earth leakage circuit breaker Fi 16/0,03 A		1561160
○ Control panels for single or twin pump stations float switch control		On request